

General Specifications

Magnetic Flowmeter AY6410 [Size: 25 to 400 mm]

GS-AY6410-01-R00

■ GENERAL DESCRIPTION

Magnetic Flowmeter AY6410 is a product specialized for water based flow measurement. It is a cost-effective solution for Water Pipelines, Industrial Water, Wastewater Treatment and Water Treatment. The AY6410 is an optimized design that focuses on the essential performance and cost efficiency.

It contributes to reducing total cost of ownership when used together with other Yokogawa flowmeters.

- Size: 25 to 400 mm
- Lining: Hard Rubber, Neoprene, PTFE, Polyurethane
- Process connection: ANSI, DIN

■ GENERAL

Measuring Principle:

When a conductive fluid flows through a magnetic field, it generates an electric potential proportional to its velocity. This induced voltage is used by the flowmeter to accurately measure the fluid's flow rate. It calculates the instantaneous flow rate, integrated flow rate, etc. from the measured flow velocity.

System Configuration:

Basic configuration: Sensor, Transmitter, Cable

	Function
Sensor	Detects the flow velocity
Transmitter	Amplifies sensor output and converts signals.
Cable(*)	Signal cable (for flow signal), excitation cable (for coil excitation)

*: Necessary for Remote type with construction separated to a sensor and transmitter. Maximum cable length is 80 m.

Main Element of Sensor:

	Function
Wetted Part	Lining, Electrodes, Earthing Rings
Non-wetted Part	Flanges, Coil Housing, Excitation coil, Measuring Tube

Note: Earthing rings provide a stable electrical reference by grounding the process fluid, ensuring accurate measurement of the induced electromotive force by the electrodes, and are fixed at two locations, upstream and downstream of the flow.

Main Element of Transmitter:

Display unit, Setting keys,
Amplifier unit (including I/Os and power supply unit)



■ CONSTRUCTION

Construction:

Two types of Integral and Remote

Type	Construction
Integral	Integrated structure of a sensor and a transmitter.
Remote	Separated structure of a sensor and a transmitter, which are connected by a signal cable and an excitation cable. These cables cannot be removed.

Process Connection:

Flange type only.

Type	Process connection
Flange	ANSI 150/300, DIN PN 10/16/25/40

Electrode construction:

Internal insertion type

Earthing Rings Construction:

Earthing Rings Plate, Earth Electrode

Wetted Part Material:

Wetted Part	Material
Lining	Hard Rubber, Neoprene, PTFE, Polyurethane
Electrode	Stainless steel 316L, Nickel Alloy
Earthing Rings	Stainless steel 316L, Nickel Alloy

Non-wetted Part Material:

Non-wetted Part	Material
Coil Housing	Carbon steel
Flange	Carbon steel, Stainless steel 304
Measuring tube	Stainless steel 304
Transmitter case	AISI10Mg
Terminal box	Aluminum alloy (GdAlSi(12)Fe)

Coating:

Transmitter: Polyurethane resin powder coating
 Sensor: Polyurethane resin solvent coating

Cable Entry:

ISO M20 x 1.5 Female

Wiring Terminal:

Screw type

Mounting:

Remote Transmitter: 2-inch pipe mounting

Grounding:

Grounding Resistance: 1 Ω or less

FUNCTIONS

Display and Setting:

Display: 2 line LCD
 Display Language: English

Communication Function:

- HART (compatible)
- RS 485 (Modbus RTU)

Output:

4 to 20 mA DC, Pulse (OC/Act)

Alarm Function:

Empty pipe and High Flowrate

* Empty pipe alarm function can be available for line size 40 mm or more.

Verification Function:

Empty pipe detection

Units:

Flow Rate	Totaliser
LPS, LPM, LPH, LPD	L, MI, m ³
MIps, MIpm, MIph, MIpd	MI
cc/s, cc/m, cc/h, cc/d	L, MI, cc, m ³
m ³ /s, m ³ /m, m ³ /h, m ³ /d	L, MI, m ³
kg/s, kg/m, kg/h, kg/d	kg, t
t/s, t/m, t/h, t/d	t
gps, gpm, gph, gpd	g, ft ³
Mgps, Mgpm, Mgph, Mgpd	Mg
lgps, lgpm, lgph, lgpd	lg, ft ³
IMgps, IMgpm, IMgph, IMgpd	IMg
ft ³ /s, ft ³ /m, ft ³ /h, ft ³ /d	g, lg, ft ³
lb/s, lb/m, lb/h, lb/d	lb
bb/s, bbl/m, bbl/h, bbl/d	bbl

PERFORMANCE

Accuracy:

Flow Velocity V m/s	Accuracy
V < 0.8	±5 mm/s
0.8 ≤ V	±0.5 % of rate ± 1 mm/s

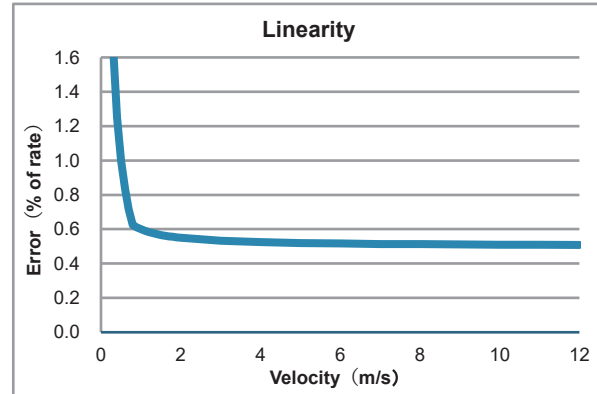

Fig.1.ai

Note: The accuracy above is the result of calibration test at our water flow facility before shipment. It is defined by the integrated value of the pulse output or the average of the current output. Reference Standards: ISO 4185, ISO 5168, ISO 20456, BS EN 29104

Repeatability: ±0.2 % of span

Measurement Range: 0.2 to 12 m/s

Power Consumption: 10 W max

Insulation Resistance:

Integral

Between power supply terminals and input/output terminals: 100 MΩ/100 V DC or 125 V DC

Between input/output terminals: 20 MΩ/100 V DC or 125 V DC

Remote Sensor

Between signal terminals: 100 MΩ/500 V DC

Between signal terminals and common terminal: 100 MΩ/500 V DC

Between excitation current terminal and signal / common terminals: 100 MΩ/500 V DC

Remote Transmitter

Between power supply terminals and input/output terminals: 100 MΩ/100 V DC or 125 V DC

Between input/output terminals: 20 MΩ/100 V DC or 125 V DC

Between input/output and excitation current terminals: 20 MΩ/100 V DC or 125 V DC

■ NORMAL OPERATING CONDITIONS

Ambient Temperature: 0 to 55°C

Ambient Humidity: 0 to 95 %

Power Supply: Power supply code P1:
 Rated Power Supply: 24V DC
 Operating Voltage Range: 18 to 60V DC

Power supply code P2:
 Rated Power Supply: 100 to 240V AC
 50/60Hz, or 100 to 240V DC

Operating Voltage Range: 80 to 300V
 AC 50/60Hz, or 80 to 300V DC

Fluid Conductivity: 20 μS/cm or higher

Fluid Temperature and Pressure:

The following figure shows the usable temperature and pressure range of the sensor in each specification. It is also limited by the flange pressure rating of the process connection.

PTFE Lining

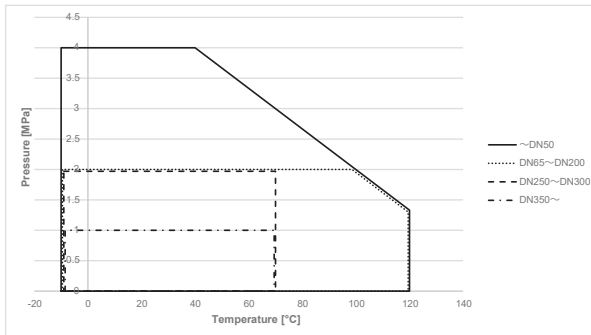

Fig.2.ai

Lining other than PTFE

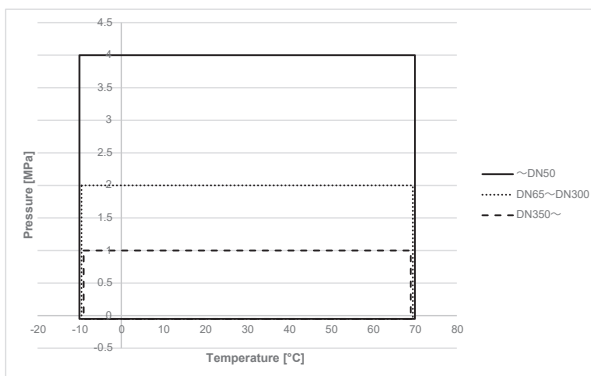

Fig.3.ai

Vibration Conditions:

Random vibration test

10Hz to 150Hz, X/Y/Z axes, 2min each

GRMS 7m/s²,

ASD level 10 to 20Hz 1m²/s³

ASD level 20 to 150Hz -3dB/octave

■ CAUTIONS ON SELECTION AND INSTALLATION

Combination:

The transmitter and the sensor shall be used only as the matched pair supplied at shipment. Operation with any other combination may prevent proper operation.

Wiring:

Don't bundle the power supply wire and other signal wire into the same wiring port.

Flow Tube Local Earthing / Grounding:

- A proper grounding of the Primary Head is very important to ensure proper functioning and accurate measurement by the Flowmeter.
- This ground is the reference ground for measurement and should not introduce any interference into the signal to be measured.
- Use 2.5 mm² or higher conductor diameter cable for Earthing.
- To prevent any electrical interferences do not connect the ground of any other heavy electrical equipment, to this ground.
- This ground also functions as the safety ground.

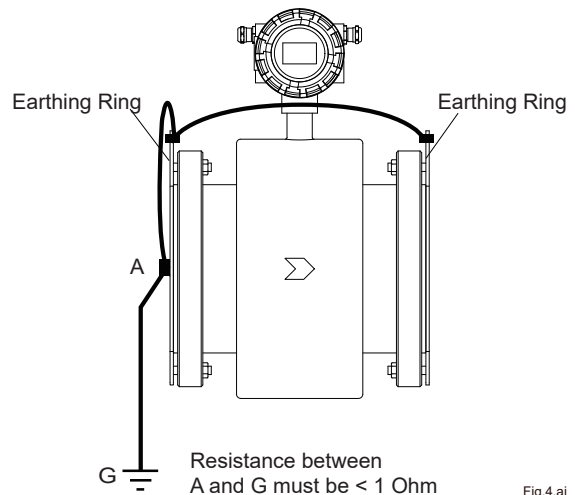

Fig.4.ai

Noise Avoidance:

The flowmeter should be installed away from electrical motors, transformers, and other power sources in order to avoid interference with measurement.

When installing two or more magnetic flowmeters, provide a distance of enough each other.

Mounting of Flowmeters and Required Straight Pipe Length:

Based on JIS B 7554 "Magnetic Flowmeters"

Maintaining Stable Fluid Conductivity:

Do not install the flowmeter where fluid conductivity tends to become uneven. If chemicals are fed near the upstream side of a magnetic flowmeter, they may affect the flow-rate's indications. To avoid this situation, it is recommended that the chemical feed ports be located on the downstream side of the flowmeter. If it is unavoidable that chemicals must be fed on the upstream side, provide a sufficient straight pipe length (approximately 50D or more) to ensure the proper mixture of fluids.

Low Conductivity Fluid:

When used for fluids with high flow noise (pure water, low viscosity and low conductivity fluid such as alcohols), the output fluctuation increases and the measurement is affected.

Selection of mounting locations

The Magnetic Flowmeters AY6410 must be installed at a point in the pipeline which satisfies the following requirements.

- a. The flow tube must be full of liquid to avoid erratic measurement results.
- b. Ensure that the Electrodes axis is horizontal within ± 15 degrees.
- c. Ensure straight pipe lengths on either ends of the flow tube – five times pipe diameter length of piping upstream and three times pipe diameter downstream from the center of the flow tube.

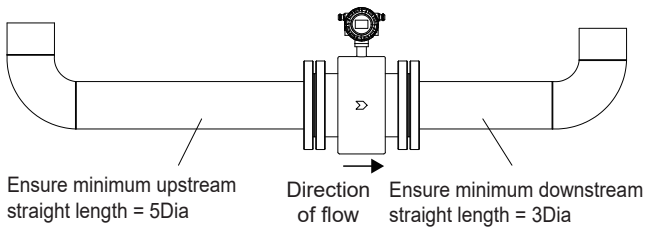

Fig.5.ai

- d. The flow tube may be installed in horizontal pipelines preferably with a slight upward gradient in the direction of flow.

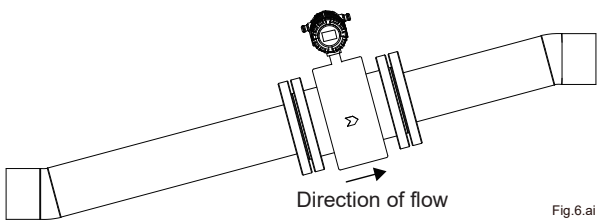

Fig.6.ai

- e. Never install the flow tube that will cause it to remain empty or partially full. Never install the flow tube in vertical pipelines with the liquid flow in the downward direction.

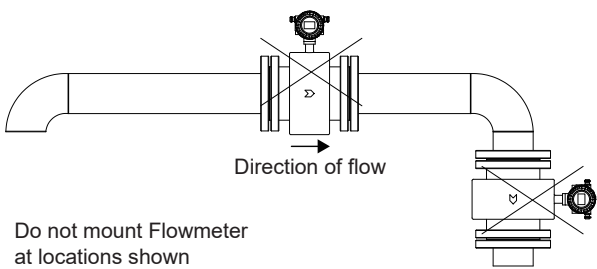

Fig.7.ai

- f. The piping layout must prevent any build-up of air. Any entrained air should be carried out of the flow tube by the liquid flow or by buoyancy at zero flow.
- g. Ensure that installation location is such that water or moisture does not enter the electrical terminations area.
- h. If the connecting pipeline is not electrically conducting or is lined with insulating material, strap the earthing rings to the detector head flanges at either end.

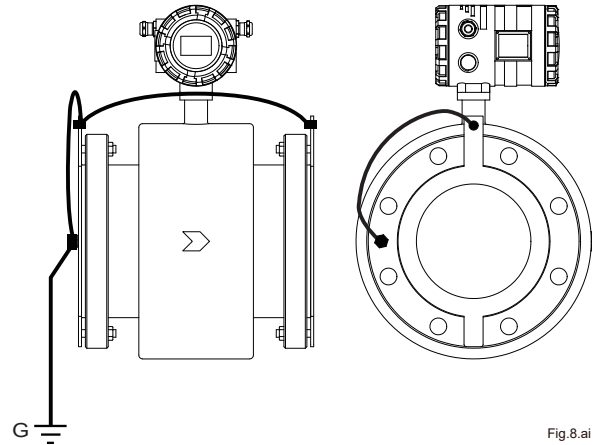

Fig.8.ai

- i. If for some reason, the complete draining out of process liquid at zero flow is unavoidable, use empty pipe detection option to obtain correct flow status and prevent erratic output.

Ordering Code

Ordering Code: M6(1)(2)(3)(4)(5)(6)(7)(8)(9)(10)(11)(12)(13)(14)(15)(16)(17)(18)

Ordering Code		Description		Limitation
Model	M6	AY6410		
1	Transmitter Type	I	Integral	
		R	Remote	
2	Power Supply	P1	24 V DC	
		P2	100-240 V AC/DC	
3	Output	OP1	4 – 20 mA DC	
		OP2	4 – 20 mA DC + Open Collector Pulse	
		OP3	4 – 20 mA DC + 24 V Active Pulse	
4	Communication Interface	C1	Not Applicable	
		C2	RS 485 (Modbus RTU)	
		C5	HART	
5	---	N	Always N	
6	Line Size	0025	DN 25	Except flange standard: S8, S17, S19
		0032	DN 32	Except flange standard: S8, S17, S19
		0040	DN 40	Except flange standard: S8, S17, S19
		0050	DN 50	Except flange standard: S17, S19
		0065	DN 65	Except flange standard: S17, S19
		0080	DN 80	Except flange standard: S17, S19
		0100	DN 100	
		0125	DN 125	
		0150	DN 150	
		0200	DN 200	
		0250	DN 250	
		0300	DN 300	
		0350	DN 350	
0400	DN 400			
7	Flange Standard / Design of Measuring Sensor	S1	Flange ANSI 150	
		S2	Flange ANSI 300	
		S4	Flange DIN PN 10	
		S5	Flange DIN PN 16	
		S6	Flange DIN PN 25	
		S7	Flange DIN PN 40	
8	Flange Material	F1	Carbon Steel	
		F2	SS 304	
9	Sensor Lining	L1	Hard Rubber	
		L2	Neoprene	
		L3	PTFE	
		L4	Polyurethane	
10	Electrode Material	E1	SS 316L	
		E3	Nickel Alloy	
11	Earthing Rings	G1	None (Earth Electrode)	
		G3	Nickel Alloy	
		G4	SS 316L	
12	Measuring Tube	T1	SS 304	
13	Coil Housing	CH1	Carbon Steel	
14	Protection Class for Sensor	B	IP 67	
		C	IP 68	Only for remote type. Sensor: IP 68, Transmitter: IP 67
15	---	D	Always D	
16	Cable Length	C1	10 meters	
		C2	15 meters	
		C3	20 meters	
		C4	25 meters	
		C5	30 meters	
		C6	50 meters	
		C7	80 meters	
		C9	NA (Not Applicable)	Select for Integral type
17	Accessories	A1	Not Required	
18	---	A0.5	Always A0.5	

■ ACCESSORIES

The following parts are shipped with the Sensor installed.

- Cable Glands:
Integral type 1set (2pcs)
Remote type 1set (4pcs)
- Mounting bracket: Remote type 1 set

Note: Accessories differ depending on the selected specifications. For the additional accessories, refer to the Earth Rings and Accessories in the Ordering Code.

■ TERMINAL CONFIGURATION

• Transmitter terminals

Remote type and Integral type

* There is a difference in some parts depending on communication interface.

In case of Integral type, the signal and excitation cables are internally connected at the factory to the [E1,G,E2,PE] and [C1,C2] terminals respectively.

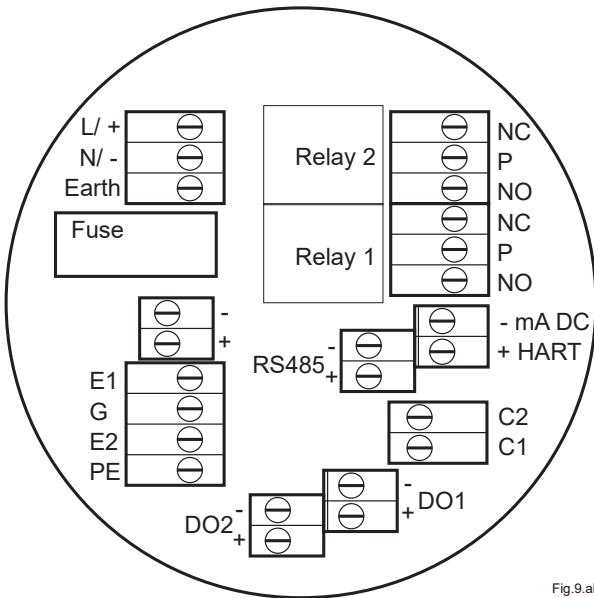

Fig.9.ai

Refer to the following table for a description of the terminals.

Marking	Description	Marking	Description
L / +	100-240 V AC/DC	24 V DC	mA DC +
N / -	Neutral	0 V DC	mA DC -
E	Earth	DO1 +	Digital output 1
C1, C2	Coils	DO1 -	
E1, E2	Electrodes	DO2 +	Digital output 2
G	Electrode ground	DO2 -	
PE	Empty Pipe electrode		
RS485 +	Modbus		
RS485 -			

* When selecting C5 or C11 for the communication interface, this terminal is use to be HART communication.

- Fuse rating: 500 mA for AC power, 1 A for DC power
Fast blow, Glass body 5x20 mm

Recommended Cable:

Power cable: 3 core, 1 mm², PVC/ PTFE sheathed cable

Current Output cable: 2 core, 1 mm², PVC/PTFE sheathed cable

Excitation Cable: Outer diameter: 5.7 mm, Nominal cross-section: 0.5 mm²

■ DIMENSIONAL DRAWINGS

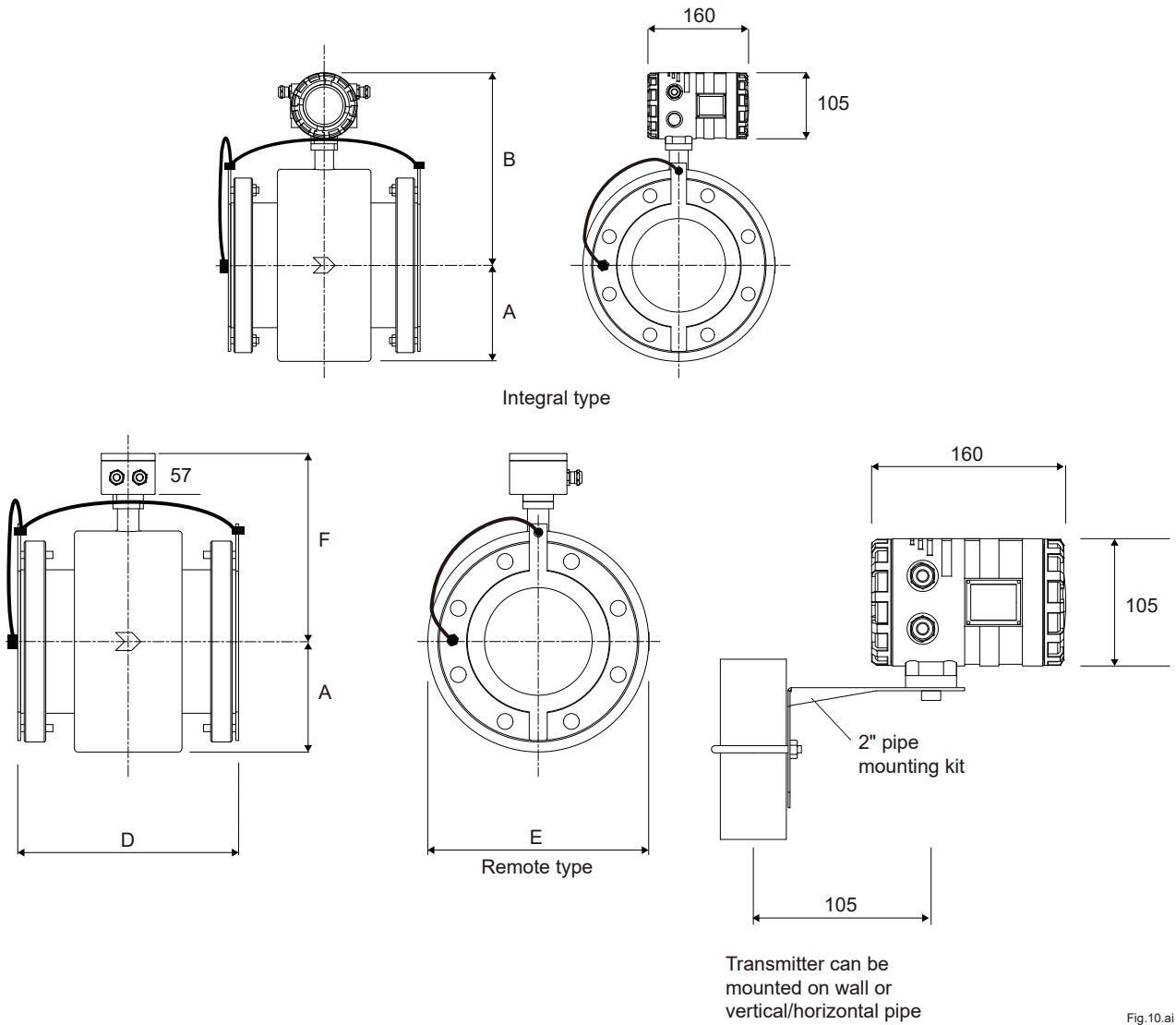

Fig.10.ai

Size	A	B	D	E	F
25, 32	73	237	200	146	180
40, 50	88	252	200	175	195
65	94	258	200	187	201
80	102	266	200	203	209
100	117	281	250	234	224
125	136	300	250	272	243
150	154	318	300	308	261
200	180	344	350	359	287
250	207	371	450	413	314
300	Refer Notes below	381	500	Refer Notes below	324
350		412	550		355
400		437	600		380

Notes:

- Tolerance for D:
 - size 10 - 200 mm: +0/-3 mm
 - size 250 mm and above: +0/-5 mm
- Unless otherwise specified, limit deviations in the drawing are specified as IS 919-1.
- Refer respective flange outer diameter for dimension E for sizes DN 300 and onward.
- Dimension A for sizes DN 300 and onward is half of the Flange outer diameter.
- Add a total of 6 mm for the two Linear protection rings to dimension "D".
- Drawing is for representations purpose only, refer table for actual dimensions.

■ ORDERING INFORMATION

1. Tag No.

The Tag No. can be specified by a combination of the characters shown in the following table.

Symbol	-	Hyphen-minus	.	Period		Space (*1)
	_	Underscore	=	Equal sign	+	Plus sign
	/	Slash	(Left round bracket)	Right round bracket
	:	Colon	#	Hash mark	!	Exclamation mark
Number	0, 1, 2, 3, 4, 5, 6, 7, 8, 9					
Uppercase letter	A, B, C, D, E, F, G, H, I, J, K, L, M, N, O, P, Q, R, S, T, U, V, W, X, Y, Z					
Lowercase letter (*2)	a, b, c, d, e, f, g, h, i, j, k, l, m, n, o, p, q, r, s, t, u, v, w, x, y, z					

- *1: Leading and trailing space characters are deleted and leftjustified, then printed on the name plate/tag plate and written to the amplifier memory.
- *2: When Communication and I/O code J# (HART communication) is specified, the lowercase letters are converted to uppercase and written to the parameter "Tag". For parameter "Long Tag", they are written in lowercase as is.

■ TRADEMARKS

HART is a registered trademark of FieldComm Group.

Modbus is a registered trademark of AEDG Schneider. All other company and product names mentioned in this document are trade names, trademarks or registered

trademarks of their respective companies.

In this document, trademarks, or registered trademarks are not marked with ™ or ®.